

DETAIL A
SCALE 5:1

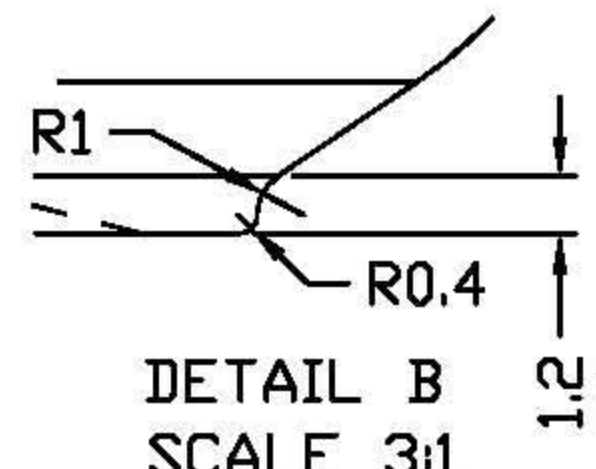

DETAIL B
SCALE 3:1

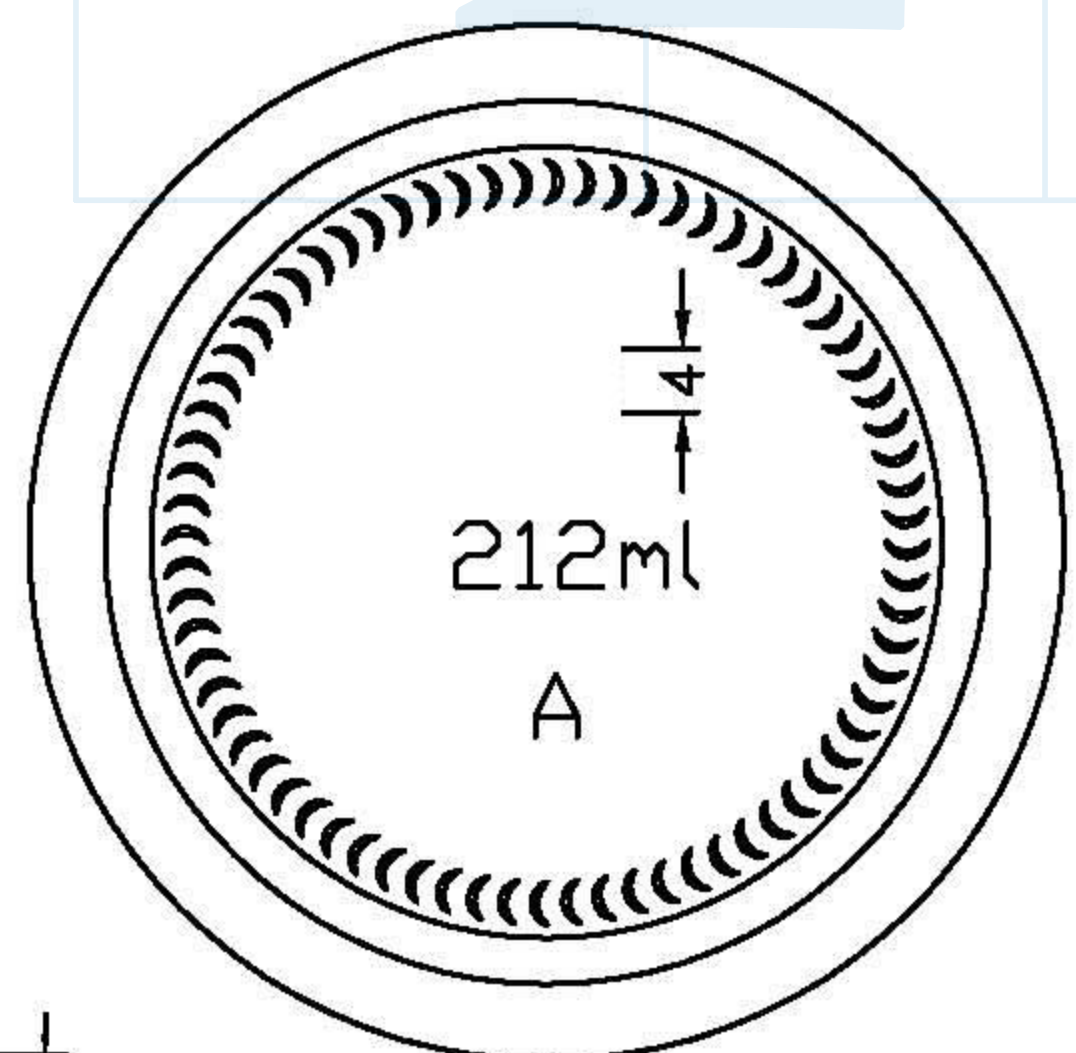

Other dimensions and information as OWENS sheets GS-217 and GS-220

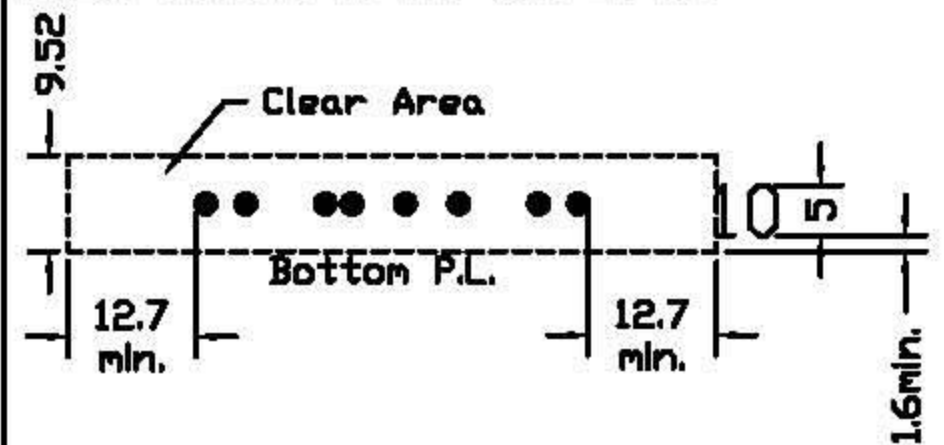

DWG No. 22005/1	Mold No.	22005	Capacity	212(±3.5)cc
	Bottle	JAR 0.212L	Fill line	
Date: 12/11/09	Customer		Weight	135(±6.5)gr
Scale: 1:1	Machine	DG 4 1/4"	Finish	63 TO BEAD
			Color	FLINT